

MANAGEMENT
&
KONSERVASI ENERGI
DI
PT. KRAKATAU STEEL

**WORKSHOP
ENERGY SERVICE COMPANY**



KRAKATAU STEEL
PARTNERSHIP FOR SUSTAINABLE GROWTH

PT Krakatau Steel (Persero) Tbk.



KANTOR PUSAT

Jl. Industri No. 5 P.O. Box 14 Cilegon, Banten 42435
Telepon : (+62 254) 392159, 392003 (Hunting)
Faksimili : (+62 254) 372246

KANTOR JAKARTA

Gedung Krakatau Steel, Lantai 4
Jl. Jend. Gatot Subroto Kav. 54 Jakarta Selatan 12950
Telepon : (+62 21) 5221255 (Hunting)
Faksimili : (+62 21) 5200876, 5204208, 5200793

PABRIK

Cilegon – Cigading Plant Site, Banten 42435
Website : www.krakatausteel.com

ESCO...?

DEFINISI ESCO

ESCO ATAU Energi Service Company adalah perusahaan yang melakukan usaha efisiensi energi dengan kontrak kinerja yang menjamin penghematan biaya energi

Karakteristik dari ESCO

- Mengkompensasi seluruh biaya dengan pengurangan biaya energi
- Menjamin pencapaian target penghematan energi dengan kontrak kinerja
- Menawarkan layanan yang komprehensif, mulai dari audit energi, kesimpulan dan rekomendasi hasil audit, perencanaan dan konstruksi peralatan hemat energi serta operasi dan pemeliharaan peralatan setelah konstruksi.
- Melakukan pengukuran dan verifikasi secara intensif atas penghematan energi yang dicapai.

KOMPENSASI UNTUK ESCO

Konsumen membayar dari sebagian penghematan biaya yang dihasilkan sebagai kompensasi untuk ESCO

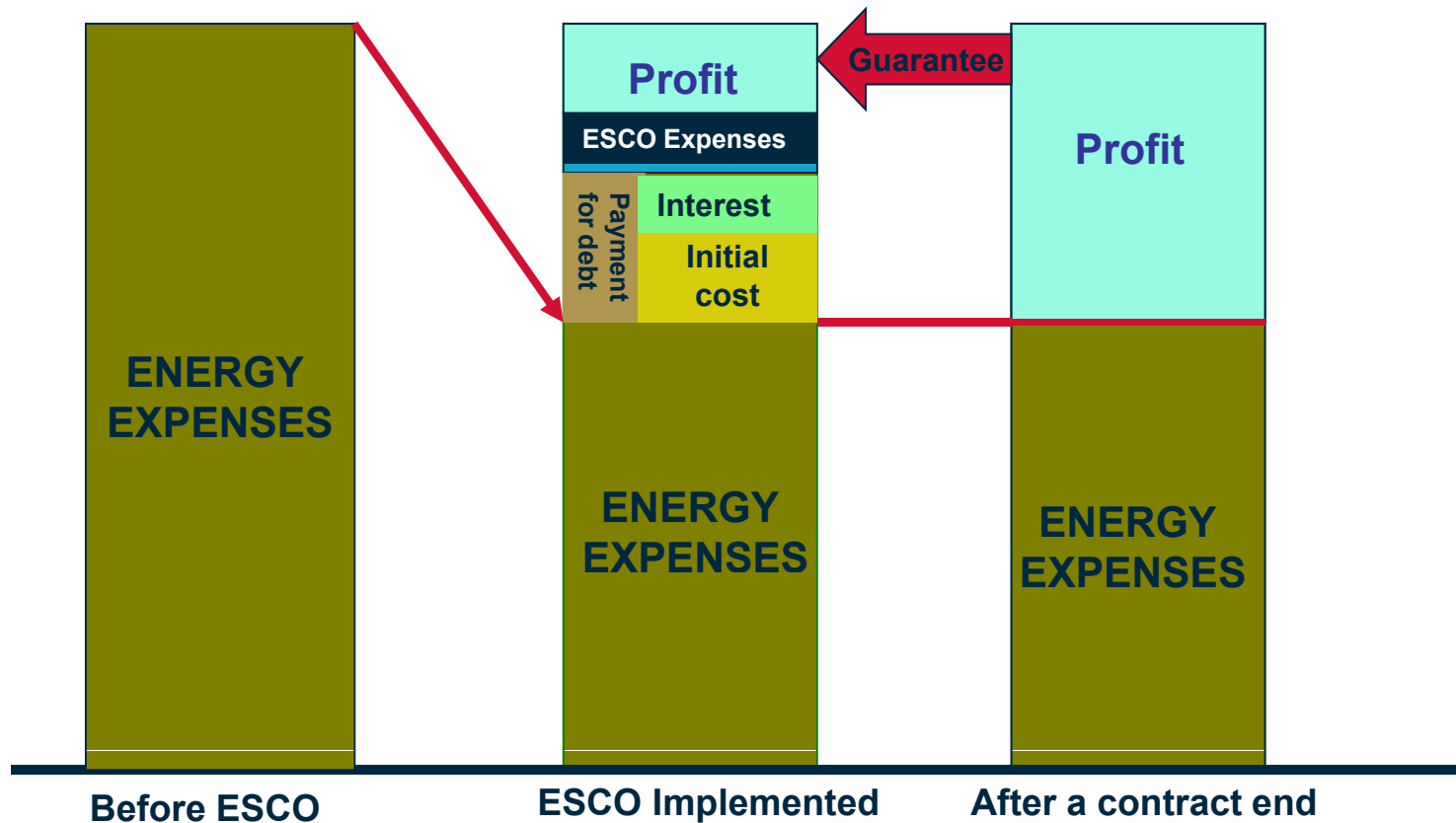

Managemen & Konservasi Energi di PT. Krakatau Steel

- Managemen Energi.

- Pengaturan operasi dan pengendalian Supply – Demand Energy
- Forcasting Supply – Demand Energy
- Optimasi Distribusi Energi
- Evaluasi pemakaian Energi
- Penetapan target pemakaian Energi

PTKS ENERGY BALANCE

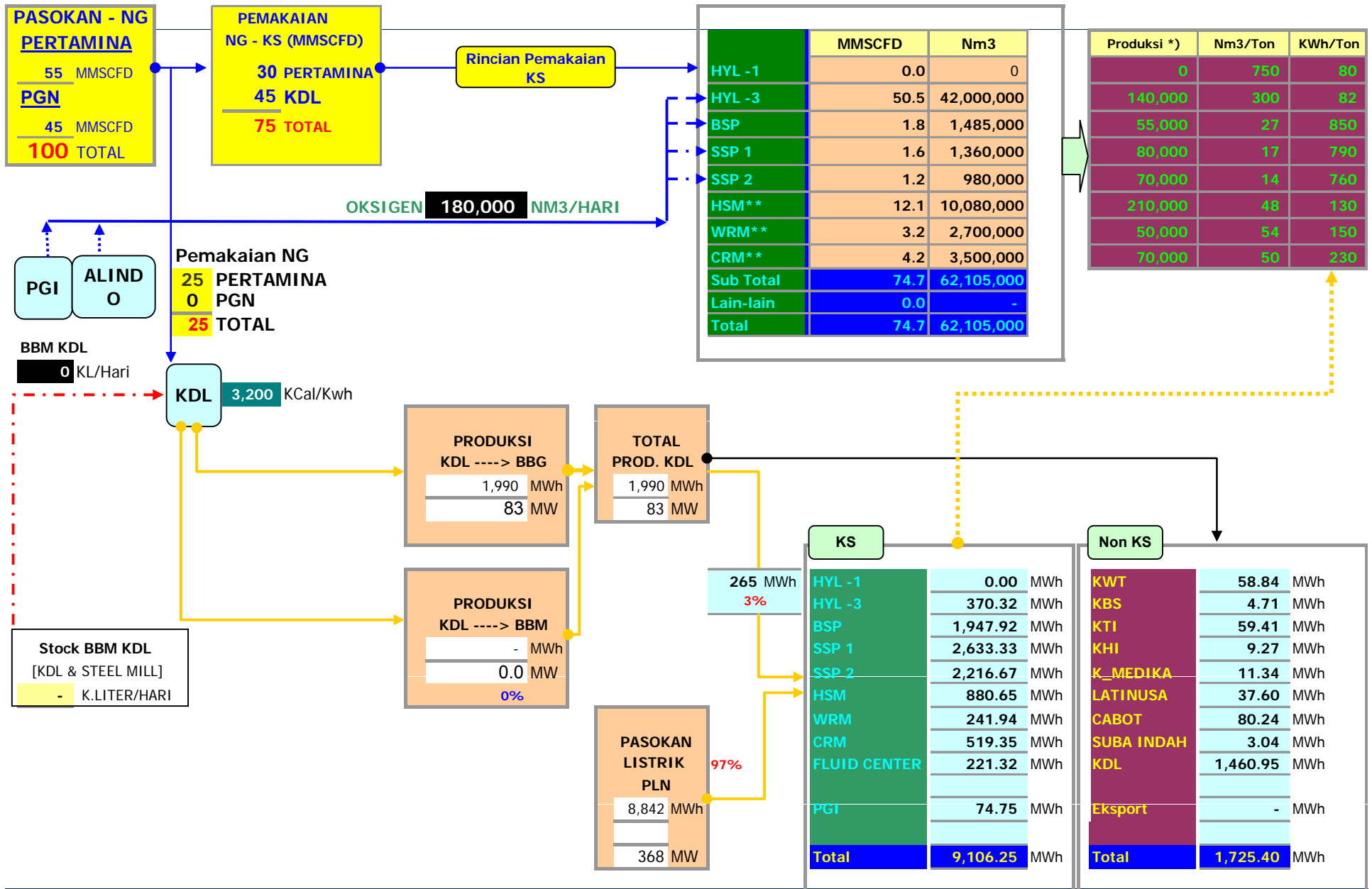

Trend Supply Natural Gas & Natural Gas Price

REALISASI KONTRAK PASOKAN GAS BUMI PERTAMINA KE PT KRAKATAU STEEL (1986 - 2010)

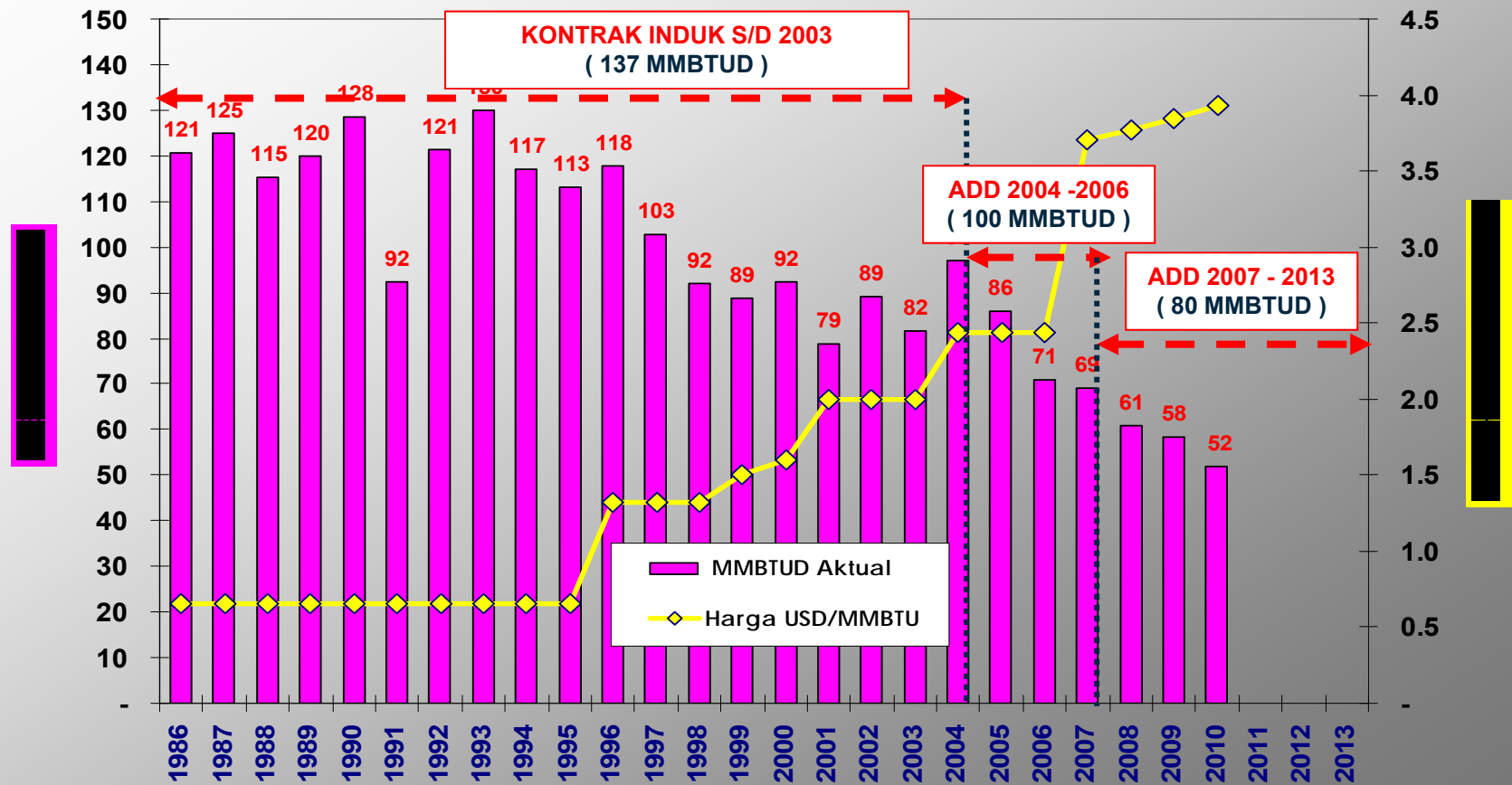



PDC On Line Monitoring

DIVISI OTOMASI



PDC On Line Monitoring

DIVISI OTOMASI



[Get PDC Data]

Data View Graphics View Advanced Select Query

Table Name: Power Monitoring

Start Date Time: 23/09/2011 22:00:00

End Date Time: 24/09/2011 08:00:00

Get Data and Create Graphic

EAF Analysis

- Tanggal
- F1Mw
- F2Mw
- F3Mw
- F4Mw
- F5Mw
- F6Mw
- F7Mw
- F8Mw
- F9Mw
- F10Mw
- EafBSP
- EafSSP1
- EafSSP2
- PLN
- KDL
- DemandKS
- FreeLoad
- BBM
- BBG

Chart Of Power Monitoring

Legend:

- F1Mw
- F2Mw
- F3Mw
- F4Mw
- F5Mw
- F6Mw
- F7Mw
- F8Mw
- F9Mw
- F10Mw
- PLN
- KDL
- DemandKS

[Get PDC Data]

Data View Graphics View Advanced Select Query

Table Name: Power Monitoring

Start Date Time: 24/09/2011 22:00:00

End Date Time: 25/09/2011 08:00:00

Get Data and Create Graphic

EAF Analysis

- Tanggal
- F1Mw
- F2Mw
- F3Mw
- F4Mw
- F5Mw
- F6Mw
- F7Mw
- F8Mw
- F9Mw
- F10Mw
- EafBSP
- EafSSP1
- EafSSP2
- PLN
- KDL
- DemandKS
- FreeLoad
- BBM
- BBG

Chart Of Power Monitoring

Legend:

- F1Mw
- F2Mw
- F3Mw
- F4Mw
- F5Mw
- F6Mw
- F7Mw
- F8Mw
- F9Mw
- F10Mw
- PLN
- KDL
- DemandKS

Konservasi Energi



PENGHEMATAN ENERGI MELALUI REPLACEMENT MOTOR LISTRIK

Reported by :

Yusuf M / Andi S / Muradi S / Uus K

ABSTRAK

- **Motor-motor listrik yang digunakan PT Krakatau Steel adalah motor-motor listrik produksi tahun 80-an memiliki efisiensi yang rendah (η) berkisar 84%~90%, sementara motor-motor listrik produksi tahun 2000-an memiliki efisiensi yang sangat tinggi (η) yaitu diatas 90%~ 95%.**
 - **Kebutuhan daya motor-motor listrik secara individu tidak besar, namun karena jumlah motor listrik sangat banyak dan beroperasi kontinyu mengakibatkan pemakaian energi listrik oleh motor-motor listrik di PT. Krakatau Steel sangat besar, yaitu hampir 1/3 dari total pemakaian energi listrik.**
 - **Peningkatan efisiensi motor listrik akan berdampak sangat signifikan terhadap upaya penghematan energi listrik, peningkatan efisiensi ini dapat dilakukan dengan penggantian motor-motor listrik efisiensi rendah dengan motor-motor listrik efisiensi tinggi.**
- 

Energy Cost Electric Motors

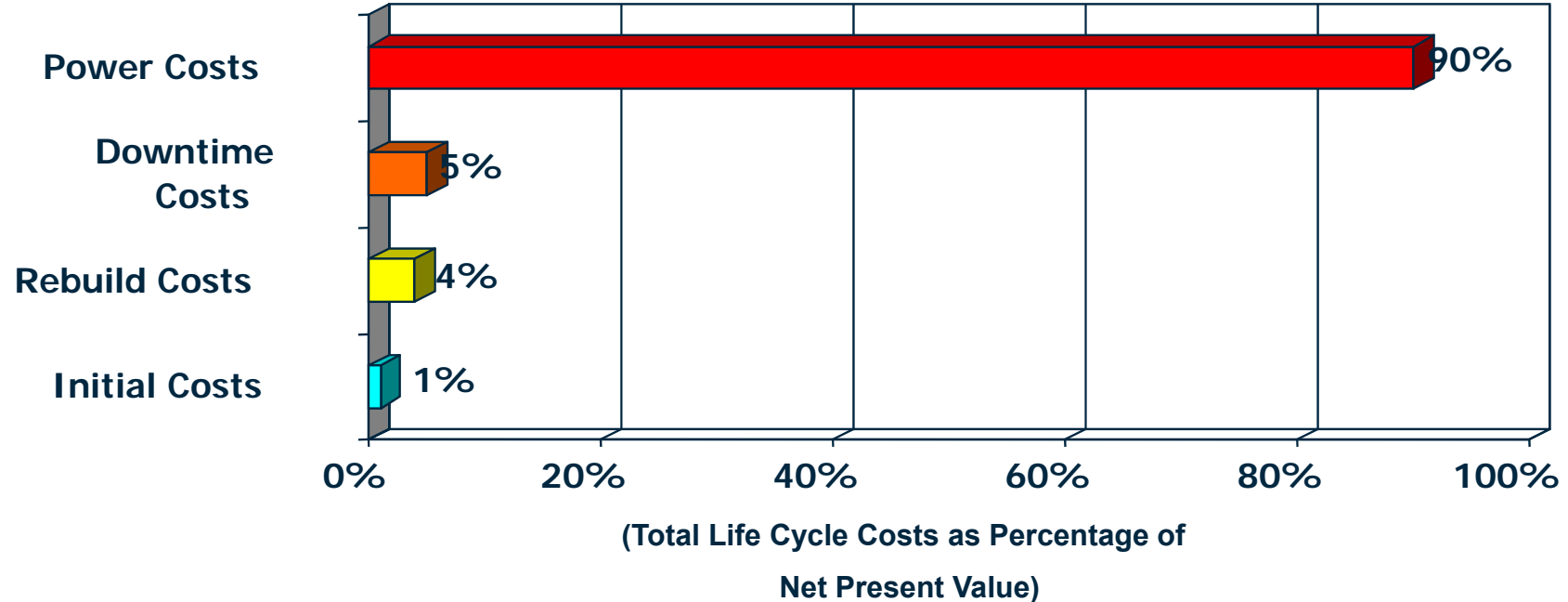
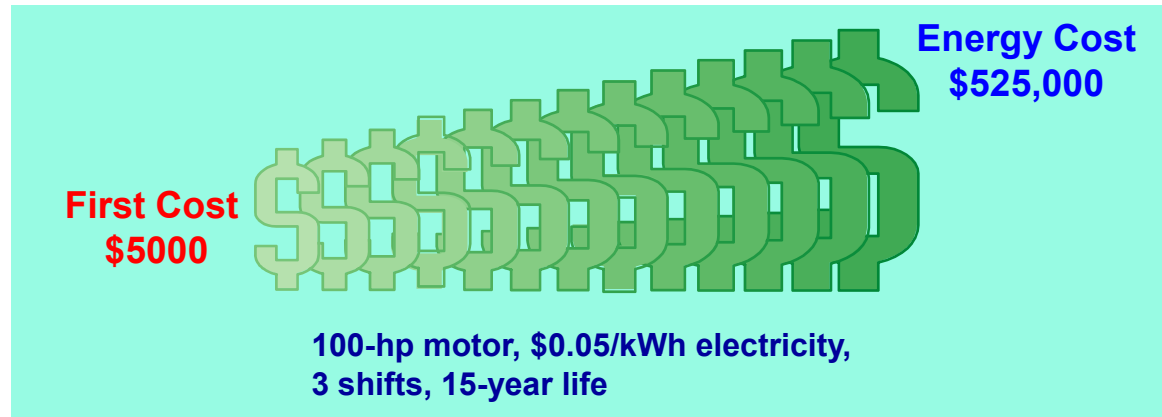

Automobile vs. 60 HP Motor

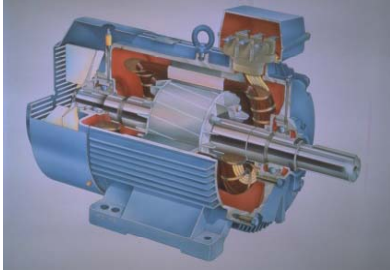
		
	<u>Automobile</u>	<u>60 HP Motor</u>
Purchase Price	\$18,000	\$4,000
Annual Use	12,000 miles/yr	4,000 hours
Efficiency	30 miles/gallon	89.2%
Fuel/Energy Cost	\$2.80/gallon	5.6 cents/ kwh
Annual Operating Cost	\$440/yr	\$10,036/yr
Operating Cost as a % of Purchase Price	2%	250%

Efficiency Comparison Motors

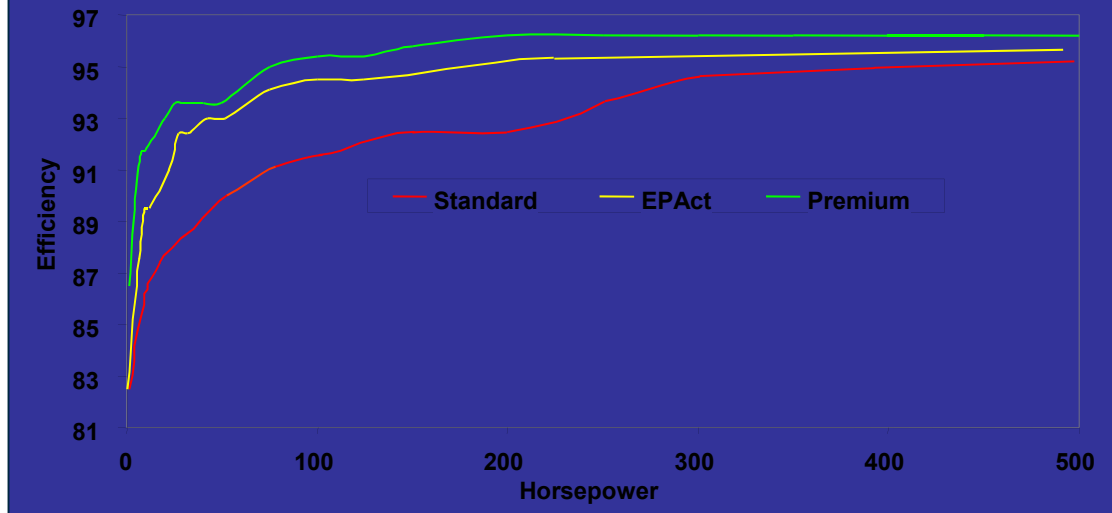

Construction Comparison Motors

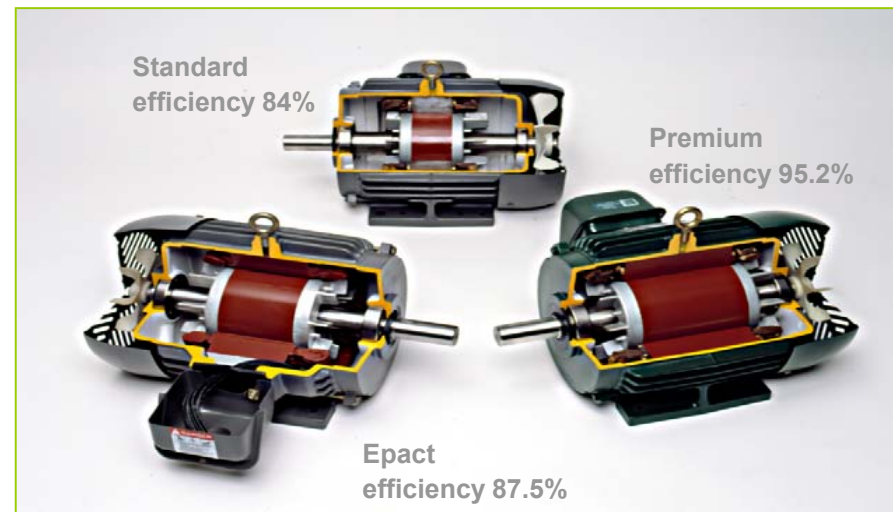

POTENSI PENGHEMATAN ENERGI MELALUI
REPLACEMENT MOTOR LISTRIK KINERJA
RENDAH (EFFISIENSI RENDAH) DENGAN MOTOR
LISTRIK KINERJA TINGGI (EFFISIENSI TINGGI)

JUMLAH MOTOR LISTRIK YANG DIREWINDING

Kap. Motor kW	Jumlah Motor			Efisiensi Motor Listrik
	2006	2007	2008	
<25 kW	109	591	440	76%
25-50 kW	8	74	52	76%
51-100 kW	16	85	32	82%
101-175 kW	5	37	33	85%
176-300 kW	-	-	-	86%
>300 kW	3	29	29	88%

Data Source : Div. Utility

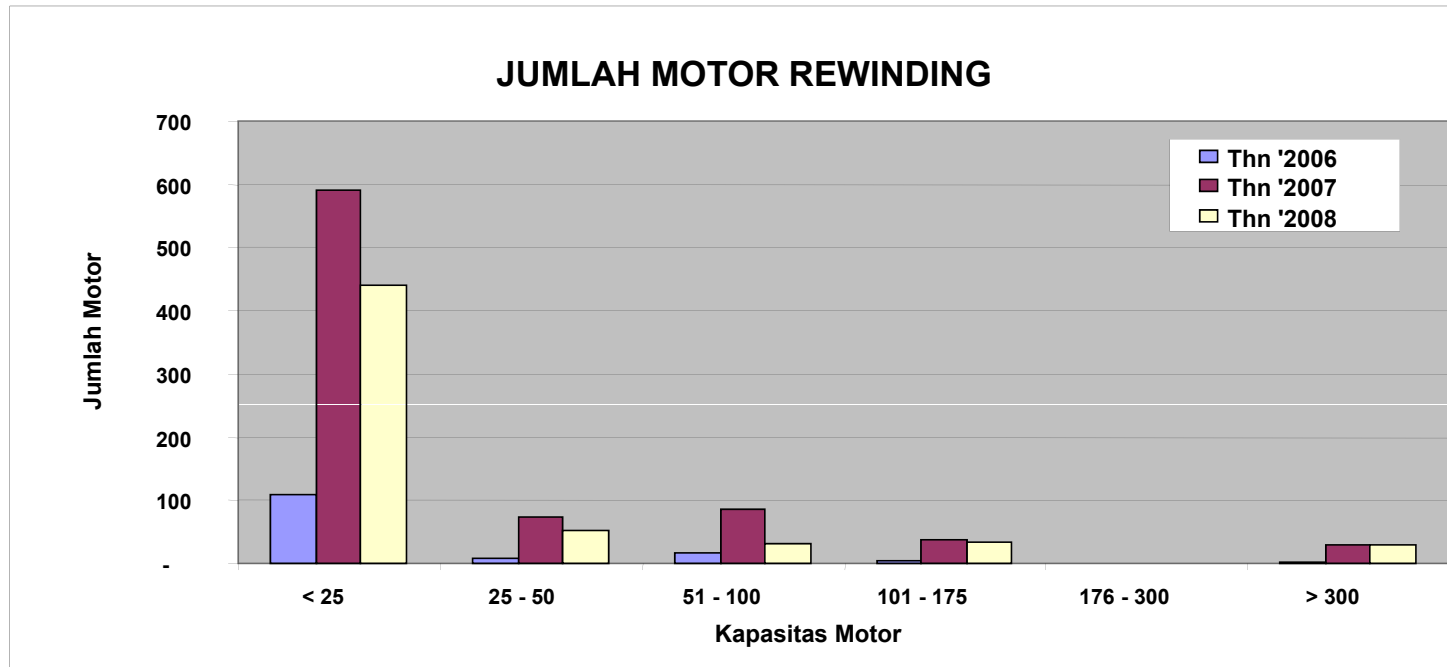

Perbandingan distribusi daya untuk menjalankan pompa air di WTP menggunakan motor listrik rewinding ($\eta=80\%$) vs motor listrik efisiensi tinggi ($\eta=95\%$)

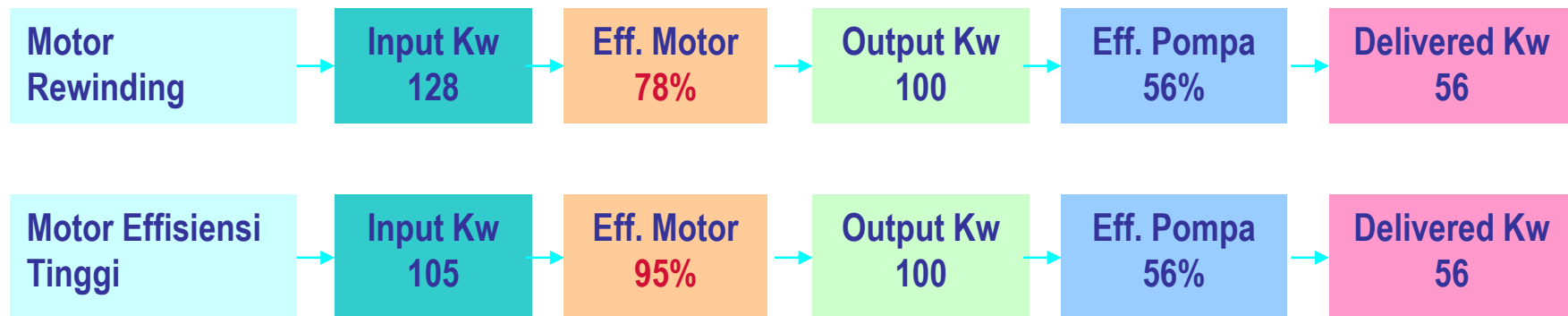

**Analisa Kelayakan Investasi Motor Listrik
Efisiensi Tinggi Untuk Mengganti Motor Listrik
Existing (Rewinding)**



TREND HARGA MOTOR LISTRIK EFFISIENSI TINGGI BERDASARKAN KAPASITAS





ABB Motor '2002

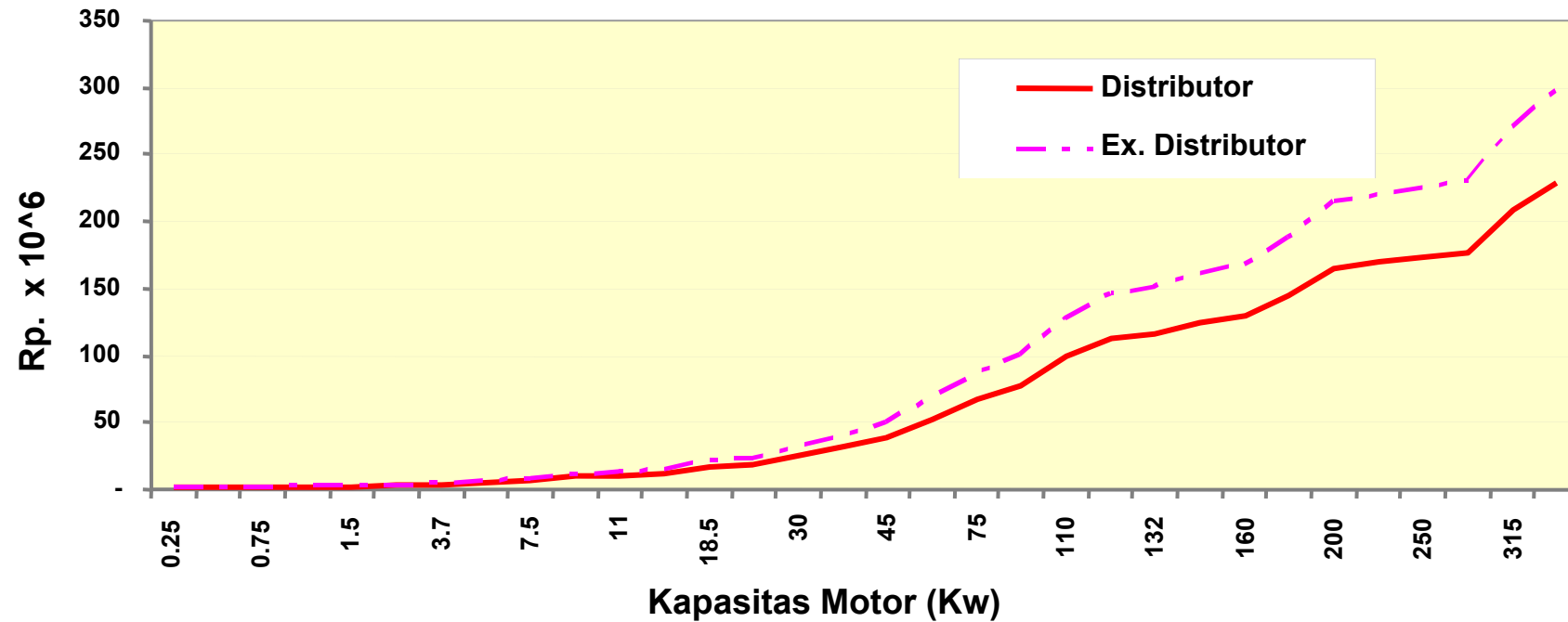
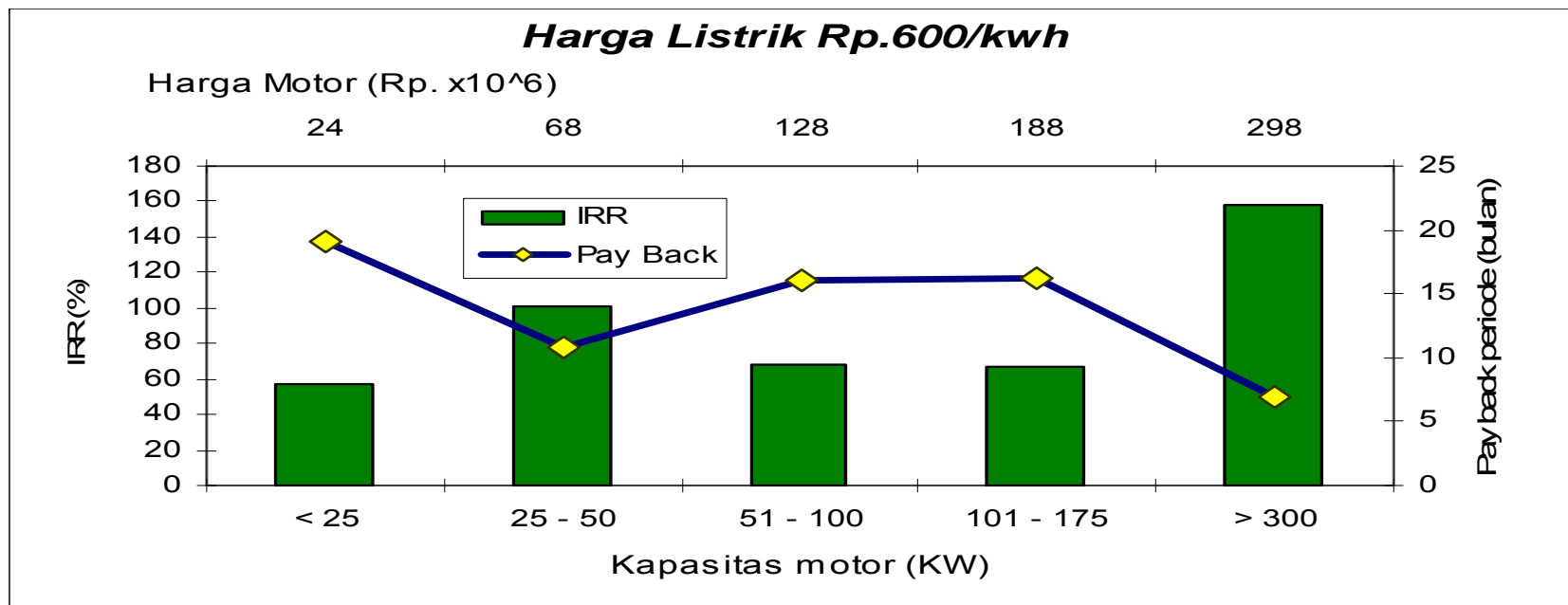
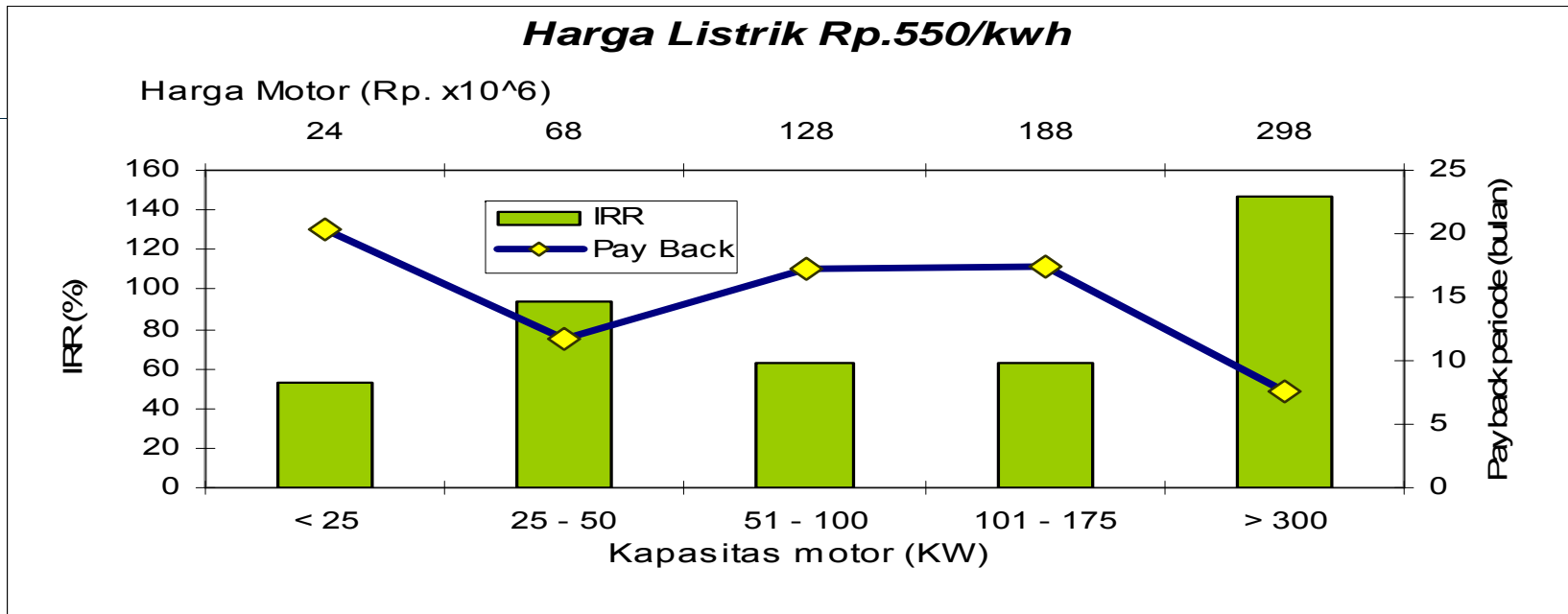

KESIMPULAN DAN REKOMENDASI

1. Dari hasil kajian diketahui bahwa setiap persentase peningkatan efisiensi motor listrik akan memberikan kontribusi yang cukup besar terhadap penghematan biaya energi, maka meskipun motor existing (standart atau rewinding) masih dapat beroperasi dengan baik namun karena effisiensinya rendah, diusulkan untuk dilakukan replacement dengan motor listrik efisiensi tinggi (baru).
 2. Mengingat banyaknya jumlah motor dan pemakaian energi oleh motor-motor listrik, maka perlu dilakukan usaha peningkatan kinerja motor (peningkatan efisiensi motor), terutama motor-motor yang dioperasikan untuk jangka waktu yang lama maupun motor-motor yang beroperasi dengan beban dinamis pada kondisi ekstrim.
 3. Memasang motor sesuai kapasitas beban yang diperlukan guna menghindari pengoperasian motor dengan beban rendah yang menyebabkan in-efisiensi dan pemborosan investasi, sehingga apabila kapasitas motor yang terpasang sesuai dengan beban maka kinerja motor menjadi optimal.
- 

IMPLEMENTASI

PERCOBAAN

Percobaan pengoperasian motor listrik efisiensi tinggi dilakukan dengan mengganti motor lama unit penggerak pompa air dengan motor baru efisiensi tinggi (Eff.1) sebanyak 2 unit di Area WTP-1.

PENGADAAN MOTOR

Pengadaan 2 unit motor baru (1pcs Kap. 55Kw Eff.1 dan 1pcs Kap. 132Kw Eff.1)

Data Teknis Motor Listrik :

No	Parameter	MOTOR LISTRIK 55 Kw				MOTOR LISTRIK 132 Kw			
		Lama		Baru		Lama		Baru	
1	Kapasitas Daya	55	Kw	55	Kw	132	Kw	132	Kw
2	Tegangan Ph to Ph	380	Volt	390	Volt	380	Volt	390	Volt
3	Effisiensi	76	%	95	%	78	%	95	%

INSTALLASI di WTP-1

Percobaan dilakukan dengan memasang alat monitoring untuk mengukur parameter motor lama dan motor baru sebagai unit penggerak pompa air di Area WTP-1 secara real time.

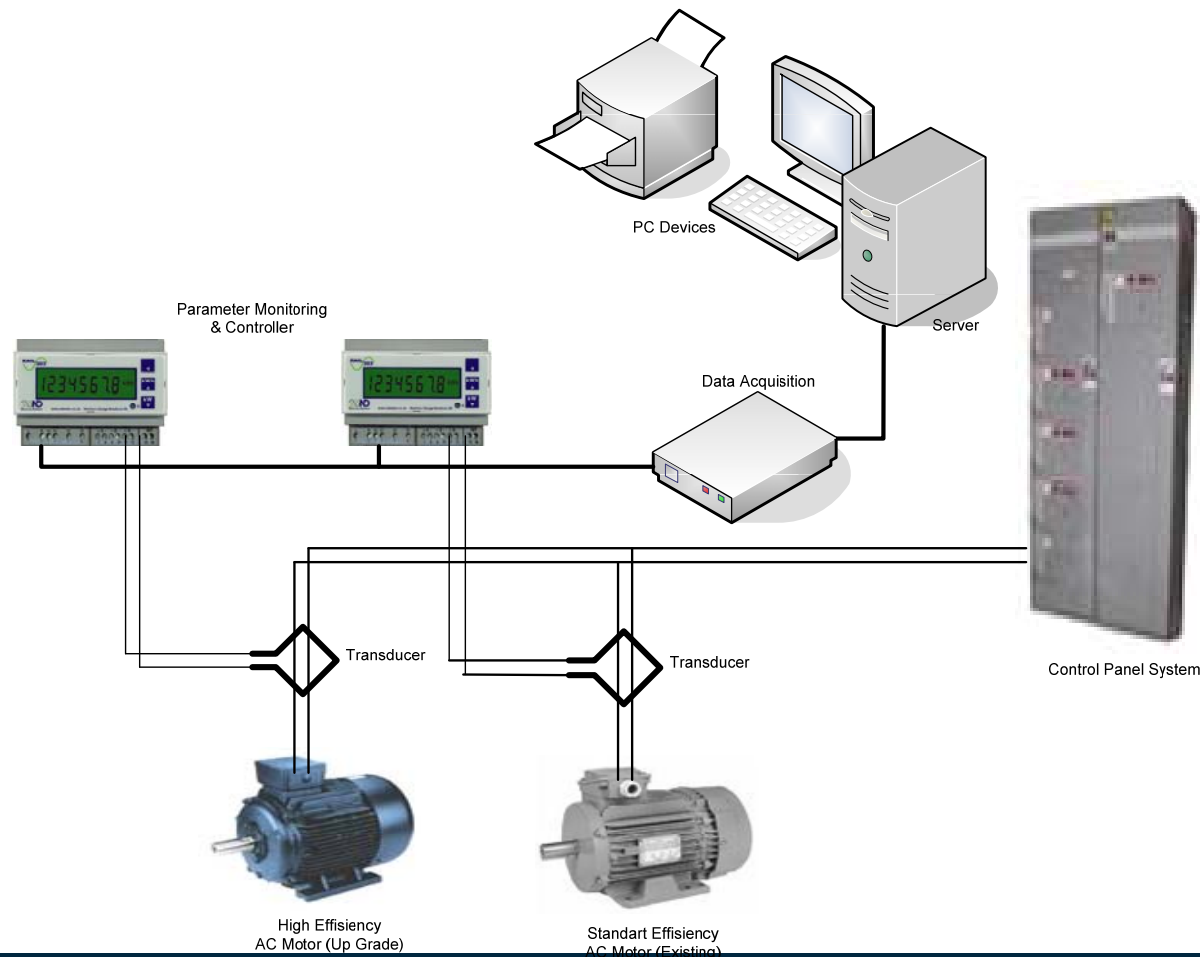

PENGUKURAN PARAMETER

Dilakukan secara real time selama motor beroperasi, dari data tersebut dapat diketahui kinerja antara motor listrik efisiensi standart dengan motor listrik baru (efisiensi tinggi).

SENTRON 2 (55 KW) P 18.3										
Data ke-	Motor Baru				Motor Lama				Penghematan	
	Total W	Total VA	Total Var	Power Factor	Total W	Total VA	Total Var	Power Factor	Total VA	%
1	41,228	48,684	26,046	0.85	42,770	52,938	30,545	0.81	4,253	9%
2	41,468	49,021	26,226	0.85	42,757	52,881	30,512	0.81	3,860	8%
3	41,351	48,956	26,192	0.84	42,833	52,179	30,107	0.82	3,223	7%
4	41,440	49,110	26,274	0.84	42,722	52,244	30,145	0.82	3,135	6%
5	41,677	49,318	26,385	0.85	42,724	52,479	30,280	0.81	3,161	6%
6	41,744	49,482	26,473	0.84	42,751	52,529	30,309	0.81	3,047	6%
7	41,610	49,397	26,428	0.84	42,714	52,742	30,432	0.81	3,344	7%
8	41,549	49,251	26,349	0.84	42,823	53,048	30,609	0.81	3,797	8%
9	41,711	49,381	26,419	0.84	42,600	52,626	30,365	0.81	3,245	7%
10	41,879	49,574	26,522	0.84	42,641	52,626	30,365	0.81	3,051	6%
11	42,171	49,900	26,696	0.85	42,521	52,413	30,242	0.81	2,514	5%
12	42,041	49,768	26,626	0.84	42,635	52,613	30,358	0.81	2,845	6%
Rata-rata	41,656	49,320	26,386	0.84	42,708	52,610	30,356	0.81	3,290	7%

SENTRON (132 KW) P 18.3										
Data ke-	Motor Baru				Motor Lama				Penghematan	
	Total W	Total VA	Total Var	Power Factor	Total W	Total VA	Total Var	Power Factor	Total VA	%
1	43,017	142,329	135,639	0.30	45,251	157,358	150,592	0.29	15,030	11%
2	43,246	143,339	136,602	0.30	44,933	155,636	148,943	0.29	12,297	9%
3	43,092	142,633	135,929	0.30	45,187	156,618	149,883	0.29	13,985	10%
4	43,216	142,602	135,900	0.30	44,970	156,008	149,299	0.29	13,406	9%
5	43,294	142,578	135,877	0.30	44,997	156,576	149,843	0.29	13,998	10%
6	43,499	144,113	137,340	0.30	44,954	155,991	149,284	0.29	11,878	8%
7	43,104	141,805	135,140	0.30	45,172	156,330	149,608	0.29	14,525	10%
8	42,959	142,697	135,990	0.30	45,083	156,067	149,356	0.29	13,370	9%
9	43,120	142,677	135,971	0.30	45,039	155,832	149,132	0.29	13,156	9%
10	43,403	143,186	136,457	0.30	45,059	156,173	149,457	0.29	12,986	9%
11	43,697	144,470	137,680	0.30	45,187	156,581	149,848	0.29	12,111	8%
12	43,552	143,887	137,124	0.30	45,289	156,760	150,019	0.29	12,873	9%
Rata-rata	43,267	143,026	136,304	0.30	45,093	156,327	149,605	0.29	13,301	9%

ANALISA HASIL PENGUKURAN

Pada grafik terlihat kinerja masing-masing motor

Motor Listrik 55 Kw

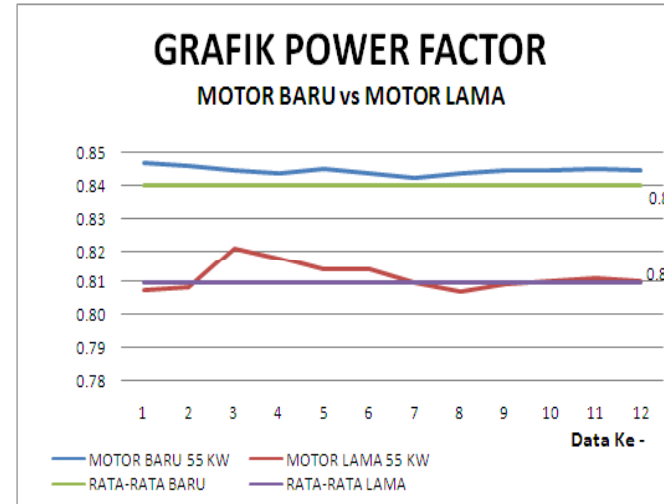
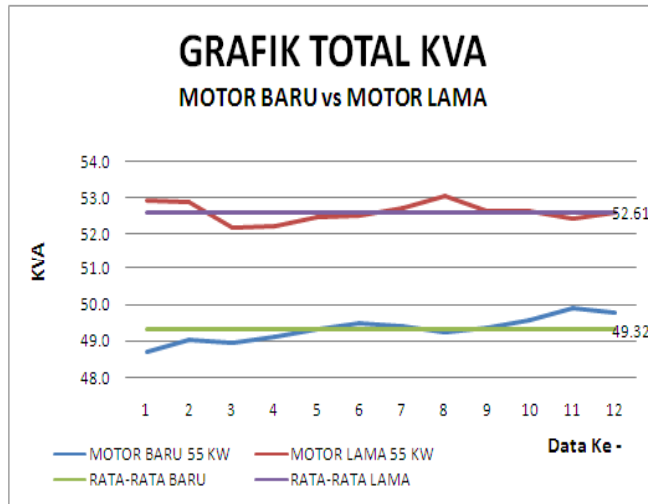

Motor Listrik 132 Kw

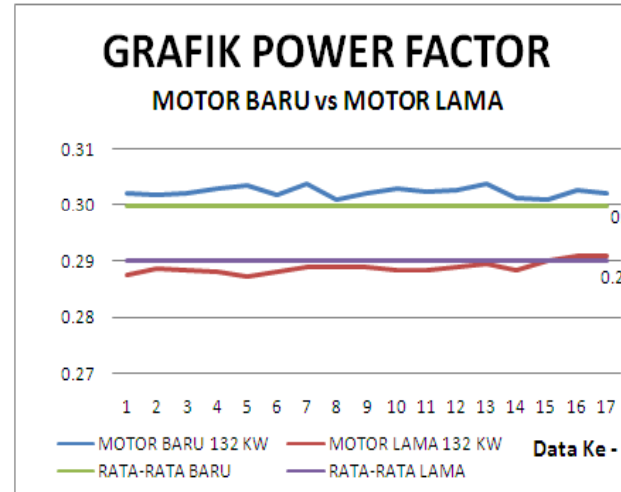
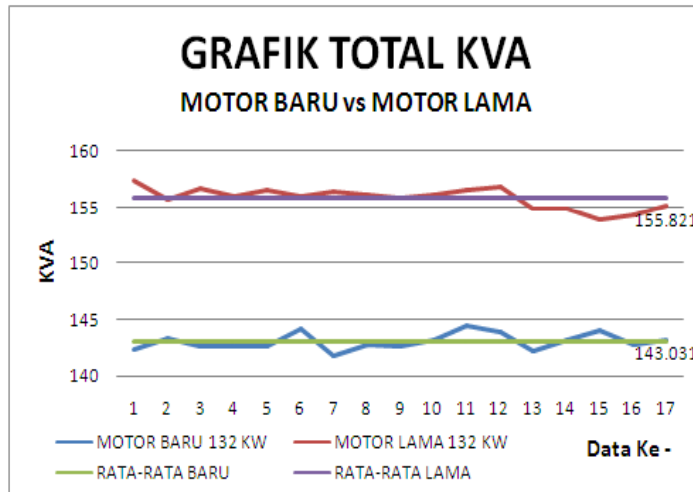

EVALUASI PENGHEMATAN BIAYA

Motor Listrik 55 Kw

KEBIJAKAN MENGOPERASIKAN MOTOR EFFISIENSI STANDART							KEBIJAKAN MENGGANTI MOTOR EFFISIENSI TINGGI							PENGHEMATAN		
Harga Motor Eff Std Rp	60		Juta				Harga Motor Eff.1 Rp	72		Juta		20%				
Tarif Listrik Rp / Kwh	600	Pada Cosφ	0.85				Tarif Listrik Rp / Kwh	600	Pada Cosφ	0.85						
Jam Operasi per Tahun	7,200						Jam Operasi per Tahun	7,200								
Kapasitas Motor	55		Kw				Kapasitas Motor	55		Kw						
Thn	Effisiensi %	Konsumsi Energi		Rp Juta			Thn	Effisiensi %	Konsumsi Energi		Rp Juta			BIAYA Rp Juta		
		Kw	Kw/Thn	Outflow	Biaya Kwh	Tot. Inflow			Kw	Kw/Thn	Outflow	Biaya Kwh	Tot. Inflow			
1	78	57	412,785	60	248	308	1	92	46	328,087	72	197	269	39		
2	78	57	412,785		248	248	2	92	46	328,087		197	197	51		
3	78	57	412,785		248	248	3	92	46	328,087		197	197	51		
4	78	57	412,785		248	248	4	92	46	328,087		197	197	51		
5	78	57	412,785		248	248	5	92	46	328,087		197	197	51		
					Total	1,298						Total	1,056	242		
Potensi penghematan tiap tahun Rp					48		Juta									

Motor Listrik 132 Kw

KEBIJAKAN MENGOPERASIKAN MOTOR EFFISIENSI STANDART							KEBIJAKAN MENGGANTI MOTOR EFFISIENSI TINGGI							PENGHEMATAN		
Harga Motor Eff Std Rp	140		Juta				Harga Motor Eff.1 Rp	168		Juta		20%				
Tarif Listrik Rp / Kwh	600	Pada Cosφ	0.85				Tarif Listrik Rp / Kwh	600	Pada Cosφ	0.85						
Jam Operasi per Tahun	7,200						Jam Operasi per Tahun	7,200								
Kapasitas Motor	132		Kw				Kapasitas Motor	132		Kw						
Thn	Effisien %	P. Input		Rp Juta			Thn	Effisien %	P. Input		Rp Juta			BIAYA Rp. Juta		
		Kw	Kw/Thn	Outflow	Biaya Kwh	Tot. Inflow			Kw	Kw/Thn	Outflow	Biaya Kwh	Tot. Inflow			
1	78	170	1,226,569	140	736	876	1	93	131	941,205	168	565	733	143		
2	78	170	1,226,569		736	736	2	93	131	941,205		565	565	171		
3	78	170	1,226,569		736	736	3	93	131	941,205		565	565	171		
4	78	170	1,226,569		736	736	4	93	131	941,205		565	565	171		
5	78	170	1,226,569		736	736	5	93	131	941,205		565	565	171		
					Total	3,820						Total	2,992	828		
Potensi penghematan tiap tahun Rp					166		Juta									

KESIMPULAN DAN REKOMENDASI

1. Dari hasil percobaan diketahui bahwa setiap persentase peningkatan efisiensi motor listrik akan memberikan kontribusi yang cukup besar terhadap penghematan biaya energi, maka meskipun motor existing dapat beroperasi dengan baik namun karena effisiensinya rendah, diusulkan untuk dilakukan replacement dengan motor listrik efisiensi tinggi.
2. Kapasitas motor harus sesuai dengan kapasitas beban yang diperlukan guna menghindari pengoperasian motor dengan beban underload maupun overload yang menyebabkan in-efisiensi dan pemborosan investasi, Kinerja motor akan optimal apabila kapasitas motor yang terpasang sesuai dengan beban.
3. Dari data pengukuran power factor terlihat motor beroperasi dengan beban tidak optimal sehingga motor bekerja secara tidak efisien. Dan pada periode mendatang rencana perbaikan dilaksanakan dengan melakukan audit beban motor.
4. Dengan mengoperasikan motor listrik efisiensi tinggi didapatkan peluang penghematan biaya energy yang cukup signifikan dengan waktu pengembalian investasi (Pay Back Periode) kurang dari 3 tahun.

RENCANA

KONSERVASI ENERGI

- **Billets Hot Charging at Wire Rod Mill Reheating Furnace.**
- **Evaporative cooling system: EAF Scenario**

Hot Charging

Category of hot charging

No	H/C Type	Temperature	Route	Description
1	DHR (Direct Hot Rolling)	950 -1000°C	Slab/Billet → Rolling	Fast transfer time Stricked Rolling Schedule Roll table system
2	DCHR (Direct Charge Hot Rolling)	700 °C	Slab/Billet →RHF → Rolling	Fast transfer time Stricked Rolling Schedule Roll table system
3	HCR Hot Charge Rolling	550°C	Slab/Billet →RHF → Rolling	Use of hot box / delivery vehicle and stored in hot conservation box
4	WRM Warm Charge Rolling	300°C	Slab/Billet →RHF → Rolling	Use of hot box / delivery vehicle and stored in hot conservation box

Saving Rate

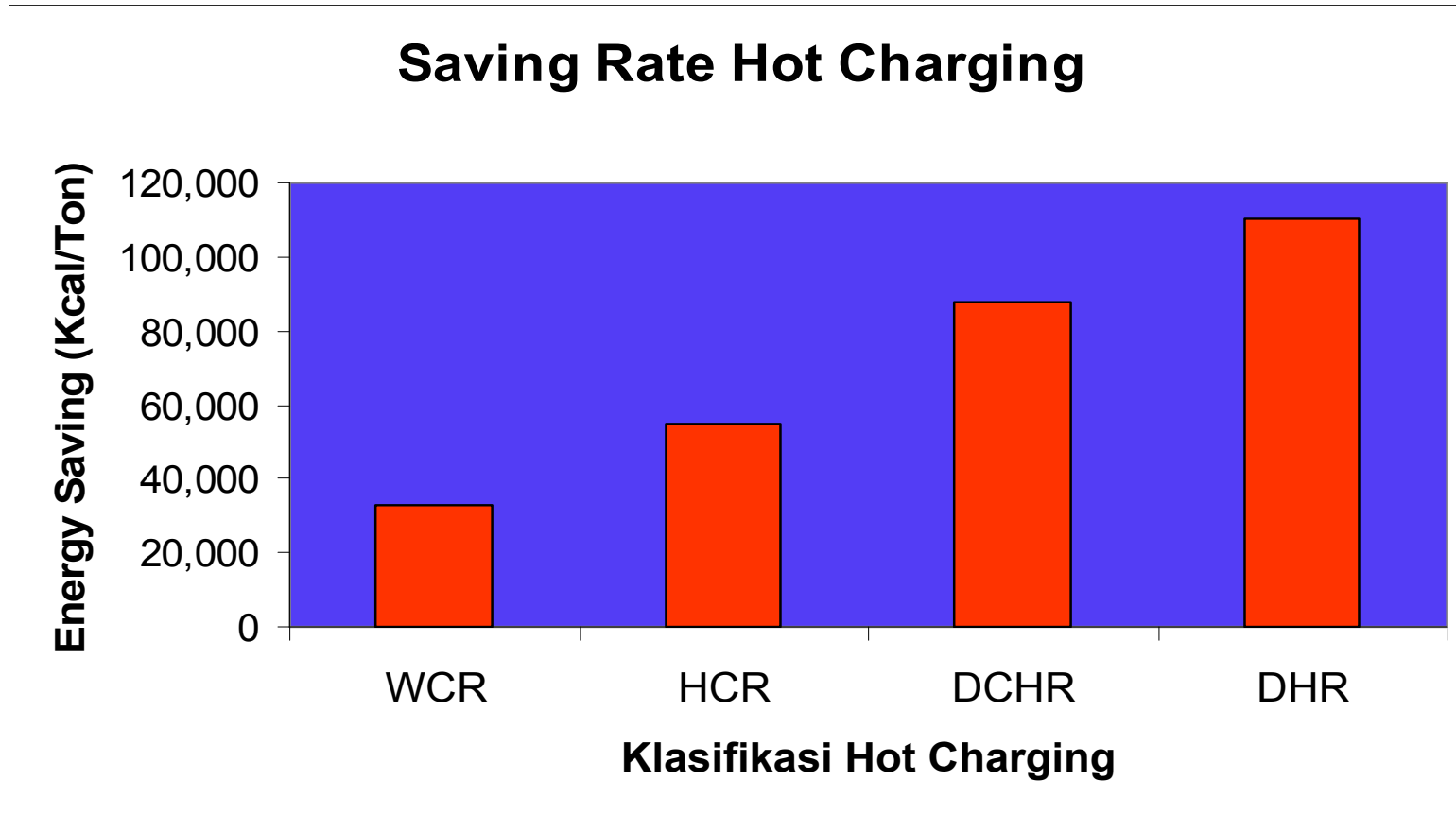

Hot Charging Saving Potential

Assume:

- furnace efficiency 45%
- 80% of billets are hot charged

**Total calor saving ($\Delta T=500$ °C)
= $2.2E+10$ kcal/year**

Price of NG = Rp 0.1885 / kcal (US\$5.0 / MMBTU)

**Saving total billet hot charging =
Rp 4,147,000,000 / year**

Techno Economy

Using irr 14%, Feasible
Investment is Rp 14.23 Billion,
and Pay Back Period 2
years

Investment Feasibility Table Hot Charging WRM

k (th)	Saving (Rp/th)	IRR	Investasi (Rp)	Depresiasi	PBP (th)
5	4,147,000,000	50%	7,201,786,008	1,440,357,202	1.29
5	4,147,000,000	25%	11,152,444,160	2,230,488,832	1.75
5	4,147,000,000	20%	12,402,068,544	2,480,413,709	1.87
5	4,147,000,000	17%	13,267,688,537	2,653,537,707	1.95
5	4,147,000,000	16%	13,578,495,782	2,715,699,156	1.98
5	4,147,000,000	14%	14,236,986,778	2,847,397,356	2.04

Billets transfer line lay out



Hot Charging

Integrated Schedule Program (software)

CCM
BSP



Casting
Schedule

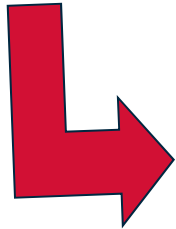

Billet
Hot
Storage

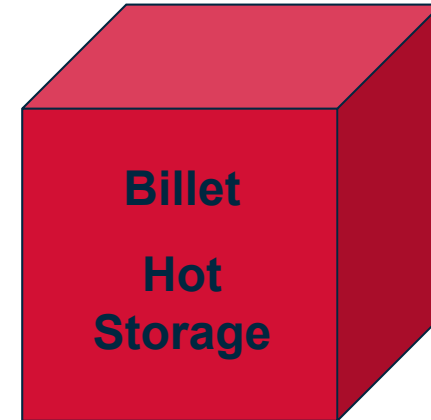

Charging
Schedule

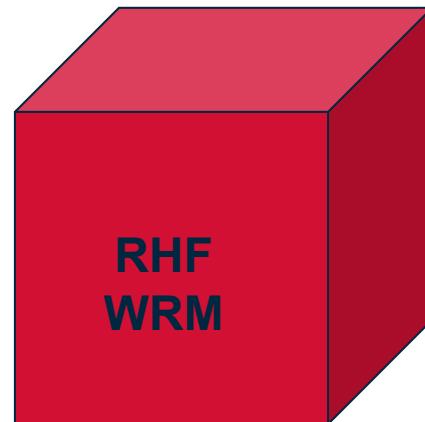

RHF
WRM

Rolling
Schedule

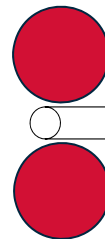

Hot Delivery Vehicle



Alternative of Billet Transportation System Modification

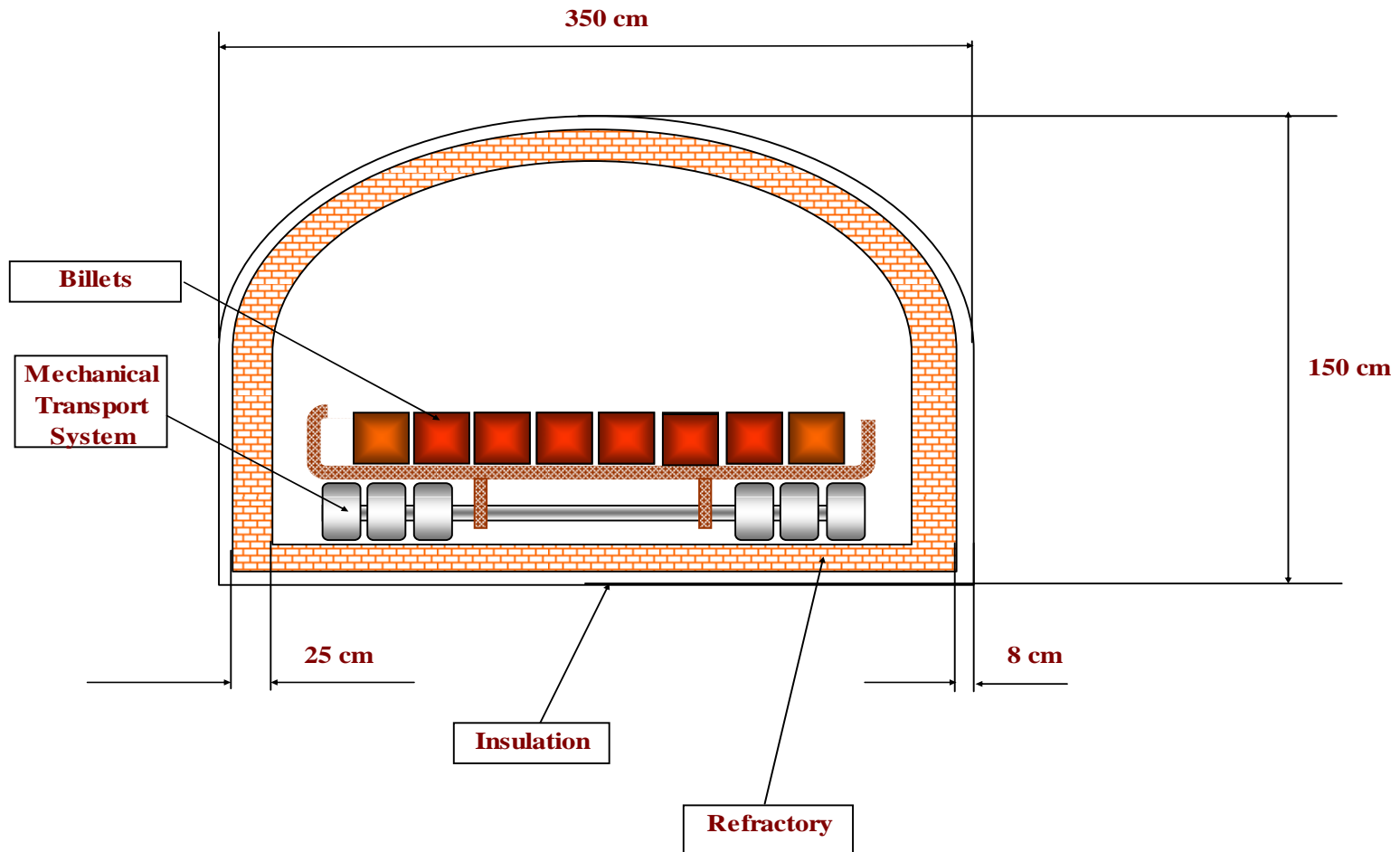

Conclusions

- 1. Hot Charging application at reheating furnace of WRM contributes energy cost saving Rp 4.147 billion / year with IRR 14 % and PBP 2 years. Cost saving would become Rp 5.184 billion/year if all (100%) of billet could be process with charging system.**
- 2. Based on the financial feasibility analysis and field condition around WRM dan BSP, transportation mode use Hot Billet Delivery Vehicle is the best alternative to be implemented. Basic design and detail design for the project will be included in engineering job.**

Evaporative cooling system: EAF Scenario

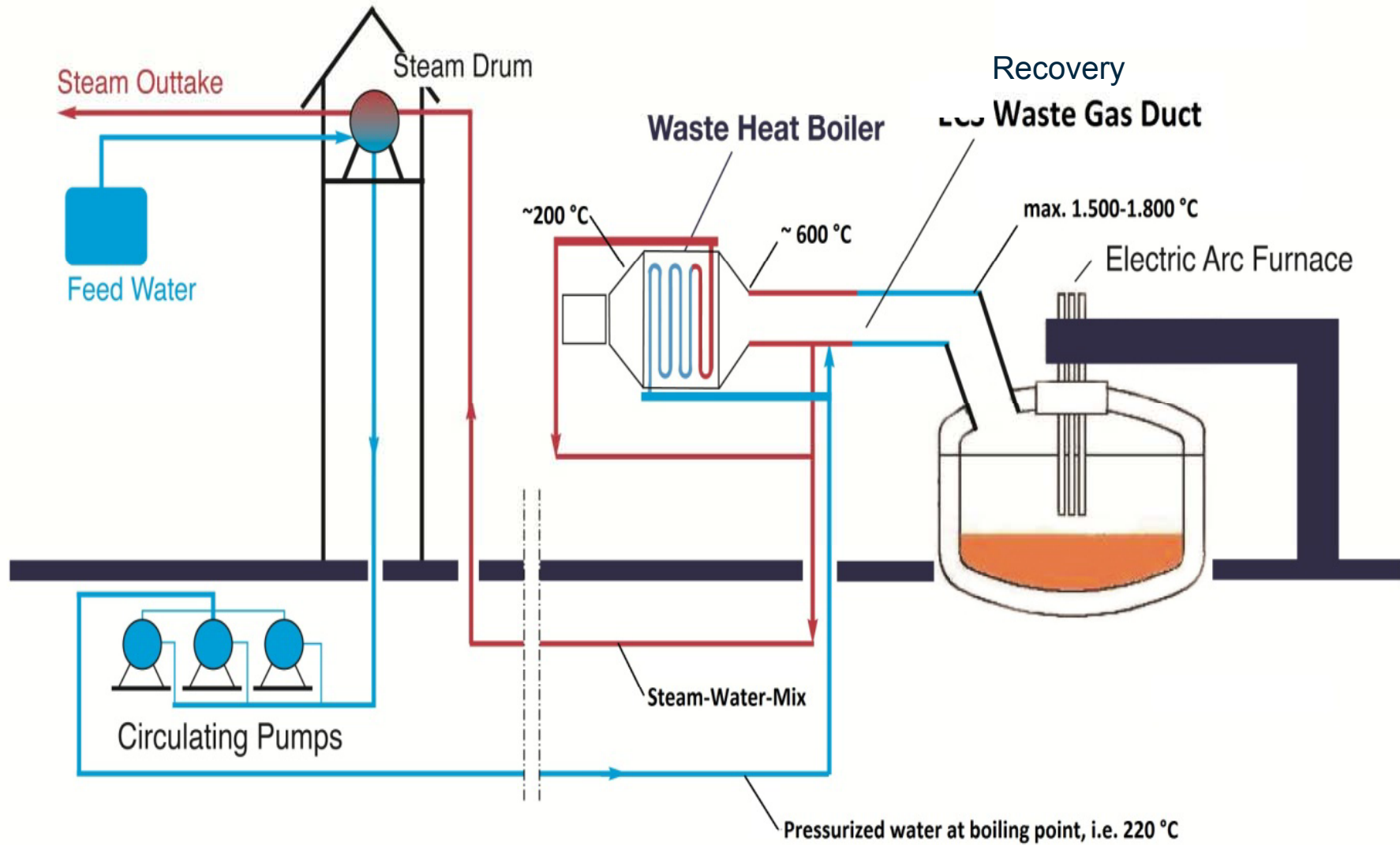

Conventional Cooling Systems (Cold Cooling)

VS

Evaporative Cooling System Technology

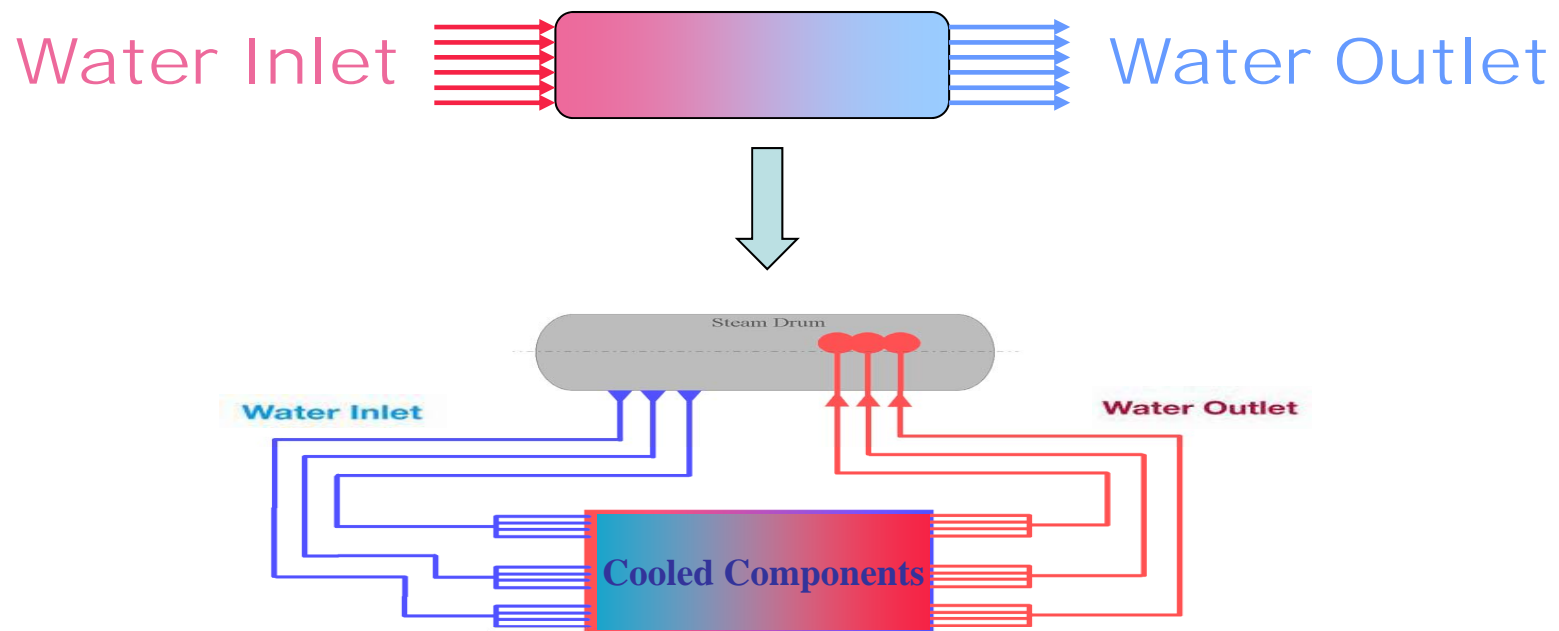

Energy balance of an EAF (150 t/h)

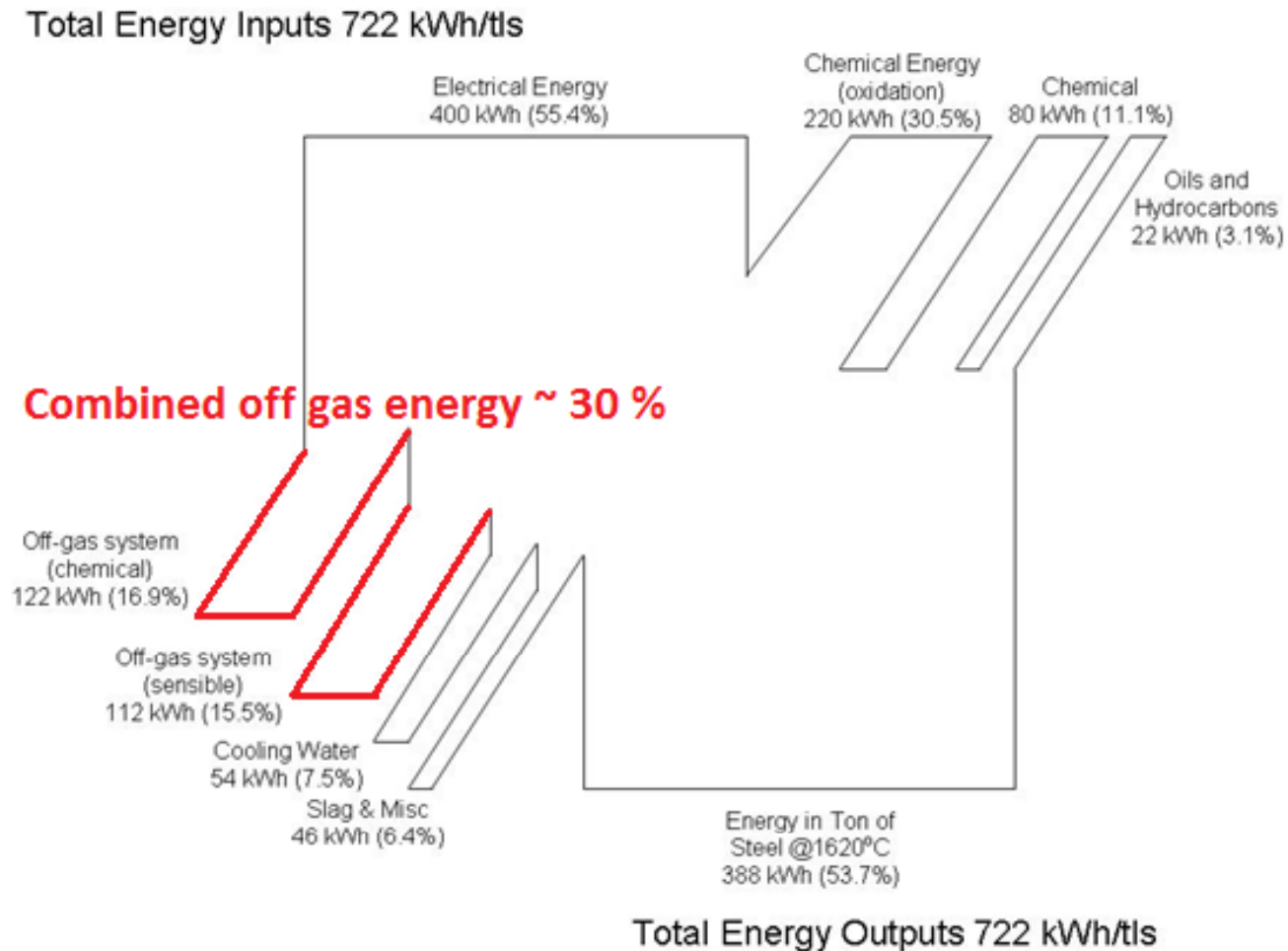

Potential of an EAF (150 t/h)

- Waste gas energy per melt:
 $230 \text{ kWh/t} \cdot 150 \text{ t} = 34.500 \text{ kWh}$
- With $t_{tt} = 50 \text{ min}$ average power = 41,4 MW
- Potential heat recovery level 1 :
 $\sim 35\% = 14,5 \text{ MW} = 22 \text{ t/h steam}$
- Potential heat recovery level 1 and level 2:
 $\sim 70\% = 29 \text{ MW} = 43,5 \text{ t/h steam}$
- **20 – 25 % of primary energy can be recovered**

